



KAISERAIR

BOEING 737-700 NEXT GENERATION

OAKLAND JET CENTER
Oakland International's
North Airport (OAK)
Oakland, California

SANTA ROSA JET CENTER
Charles M. Schulz
Sonoma County Airport (STS)
Santa Rosa, California

CONTENTS



- 2 ABOUT KAISERAIR
- 3 GENERAL INFORMATION
- 4 SEATING DIAGRAM
- 5 KAISERAIR CHARTER CONTACTS



ABOUT KAISERAIR



KaiserAir is owned, managed and operated by professional pilots with a passion for flying - and a long history of serving corporate executives and private clients from around the world.

KaiserAir dates back to 1946 when it was established as the flight department of industrialist Henry J. Kaiser's family of companies. He was a perfectionist, who instilled standards of excellence that infuse our corporate culture today. Thanks to these standards, we have maintained a perfect safety record for more than 65 years of flying.



GENERAL INFORMATION



The Boeing 737-700 Next Generation airliner is the world's most popular, reliable and successful commercial jet transport.

This aircraft is Next Generation (NG) and incorporates 21st century design technology and improvements.

Boeing 737-700NG provides superior transcontinental and intercontinental travel (including across the Pacific Ocean). Its spacious 60 seat all first-class cabin offers relaxing comfort and premier in-flight dining services upon request.

Personal DVD Players are available with accompanying onboard selection of movies.



SEATING DIAGRAM

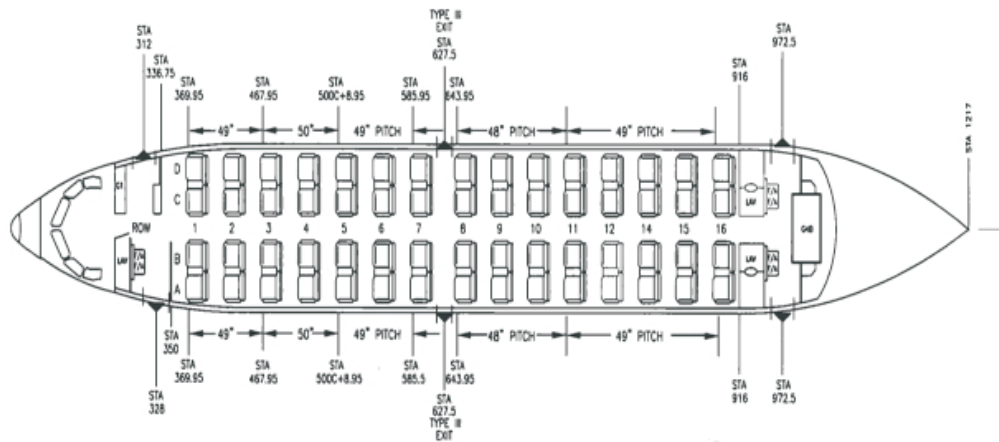

- Seating Configuration
- 60 All VIP Seats
 - Leather Interior
 - Exceptional Storage Space



KAISERAIR CHARTER CONTACTS



Oakland Jet Center
Oakland International's
North Airport (OAK)

Tina Ribeiro, Boeing Charter Coordinator
(510) 553-8433
Email: tina.ribeiro@kaiserair.com

Michele Sullivan, Boeing Charter Coordinator
(808) 938-9050
E-mail: michele@kaiserair.com

Visit us online: www.kaiserair.com



At KaiserAir, employees with jobs that directly affect the safety and security of passengers, flight crews and aircraft are subject to scrupulous checks. A pre-hire fingerprint check and thorough background investigation are conducted. During employment, flight crews and maintenance and line service technicians are tested at random for drug and alcohol use.